

SAE Companion Flanges

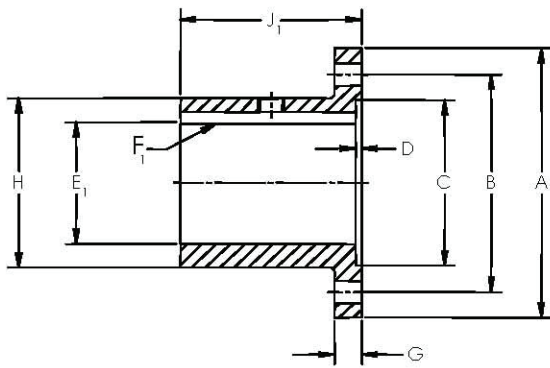

SF - Standard Flange

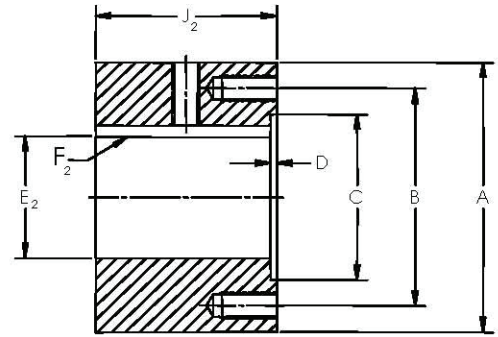

SLF - Standard Large Flange

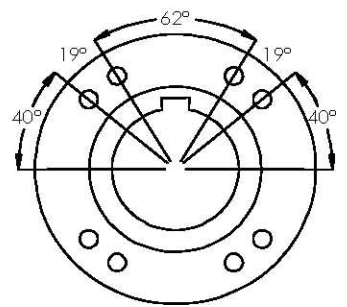
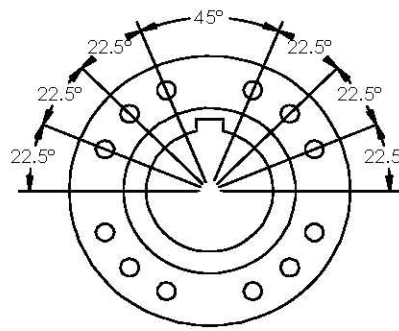
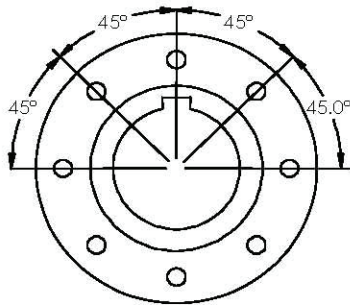
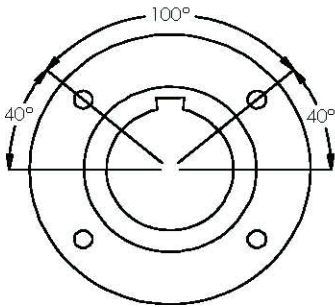

Style # 1 Style # 2 Style # 3 Style # 4

Parameter	Description	Series						
		1310	1350-1410	1480-1550	1610	1710	1810	1880
--	Style #	1	1	1	2	2	3	4
--	Number of Bolts	4	4	4	8	8	12	8
--	Thread Size	3/8-24	7/16-20	1/2-20	3/8-24	3/8-24	7/16-20	5/8-18
A	Outside Diameter	3.875	4.562	5.875	6.875	8	8	9.625
B	Bolt Circle	3.125	3.75	4.75	6.125	7.25	7.25	8.25
C	Pilot Diameter	2.375	2.75	3.75	6.625	7.75	7.75	7
D	Pilot Depth	0.078	0.078	0.094	0.063	0.063	0.063	0.141
E ₁	Maximum Bore (SF)	1.69	1.88	2.44	3.12	4	4	4.63
E ₂	Maximum Bore (SLF)	2.73	2.75	3.75	4.5	5.5	5.5	6.38
F ₁	Maximum Keyway (SF)	3/8 x 3/16	1/2 x 1/4	5/8 x 5/16	3/4 x 3/8	1 x 1/2	1 x 1/2	1-1/8 x 9/16
F ₂	Maximum Keyway (SLF)	5/8 x 5/16	3/4 x 3/8	1 x 1/2	1-1/8 x 9/16	1-1/4 x 5/8	1-1/4 x 5/8	1-1/4 x 5/8
G	Flange Width	0.38	0.38	0.38	0.44	0.44	0.44	0.63
H	Hub Diameter	2.44	2.88	3.75	5.25	6.38	6.38	6.88
J ₁	Length (SF)	2	2	2.5	3.5	4	4	5
J ₂	Length (SLF)	2.5	3	3	4	5	6	6
--	Rough Bore Dia (SF)	0.75	1	1.25	1.25	1.25	1.25	1.25
--	Rough Bore Dia (SLF)	1.25	1.5	1.5	2	2	2	4.25
--	Average Weight in Lbs (SF)	2.5	3.5	7	17.5	31	29	46.5
--	Average Weight in Lbs (SLF)	6	10	19.5	34	62	61.5	72